

**TIER IV  
COMPLIANT!**

# THE DUST DESTROYER

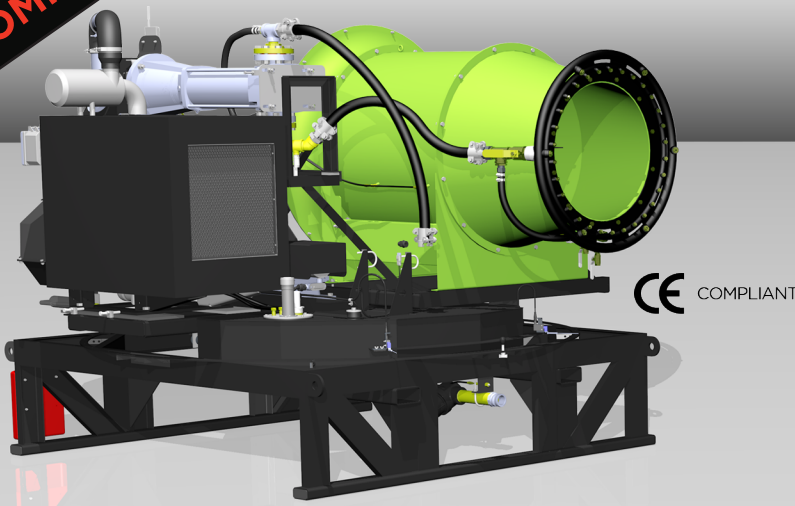

## DD-300 & HAWC-250 SHARED SPECS

### GENERAL SPECIFICATIONS

- Oscillator gives 30-360° of reversible movement
- Electronically controlled aiming for oscillation function
- Powered adjustable angle of throw 0-35° of height adjustment minimum
- 360° of powered position adjustment
- Central lubrication where practical using Beka-Max components
- 1,000' line of sight radio remote control with complete unit emergency shutdown
- Single control point for "at machine" operation (engine and other functions)
- 5-6 gallon per hour fuel consumption

### NOISE LEVEL

- 0 ft = 104 dBA
- 12 ft = 93 dBA

### DD-300 specs

Dimensions: 8.5'W x 8.9'L x 7'H

Weight: 7,630 lbs

- 37,500+ CFM generated by 42 HP fan
- Water throw of 300+ feet, 196,000 sq ft coverage
- In-line filter included. (80 mesh, 177 micron)
- 1/2 HP, 12 VDC oscillator motor
- 10,100 feet per minute fan outlet air velocity
- Logan electric over hydraulic clutch
- Murphy electronic controls

\*Water mist throw distance based on 1,000 ft elevation testing

### PRIMARY (30) NOZZLE RING

WATER PRESSURE (PSI)	40	60	80	100	120	140	150
WATER FLOW (GPM)	12.0	14.6	16.9	18.9	21.0	22.5	23.3

### SECONDARY (6) NOZZLE RING

WATER PRESSURE (PSI)	40	60	80	100	120	140	150
STANDARD WATER FLOW (GPM)	30	37	43	47	52	55	57
OPTIONAL WATER FLOW (GPM)	60	73	85	95	104	111	114

### Cummins QSF3.8L Tier 4F Diesel Engine

- 100 HP continuous duty, EPA Tier IV diesel
- 306 lb-ft (415 N-m) @1600 RPM
- 232 in<sup>3</sup> (3.8L) displacement
- Turbocharged, charge air cooled, & EGR
- 16.9:1 compression ratio
- Bosch HPCR fuel system
- 50 gallon fuel tank

