

C.W. Machine
WORX

The Manufacturing Division of Company Wrench

DUST SUPPRESSION

PRODUCT GUIDE



- DUST CONTROL • EVAPORATION • IRRIGATION
- MATERIAL RETENTION • ODOR CONTROL
- ALTERNATIVE DAILY COVER

U.S. PATENTS

8,657,941 B2 & 8,864,889 B2

AND OTHER PATENTS PENDING

ELECTRIC UNIT AVAILABLE

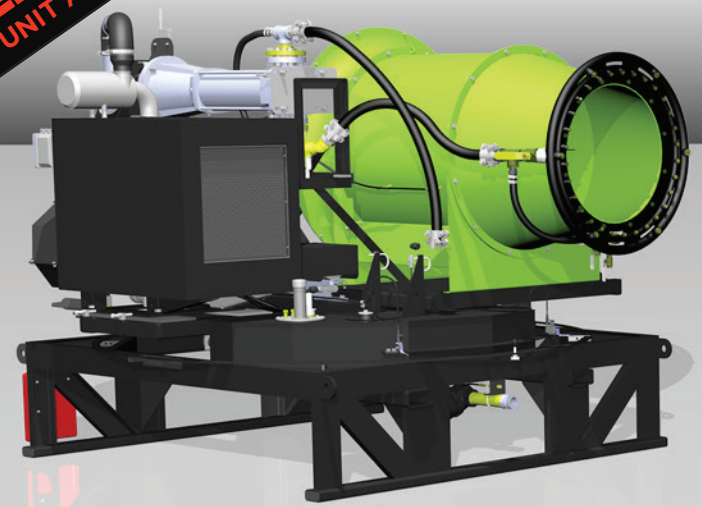

HAWC 300-80-D specs

Dimensions: 8.5'W x 8.9'L x 7'H

Weight: 5,900 LBS

- 37,500+ CFM generated by 42 HP fan
- Water throw of 300+ feet, 196,000 sq ft coverage
- In-line filter included. (80 mesh, 177 micron)
- 1/2 HP, 12 VDC oscillator motor
- 10,100 feet per minute fan outlet air velocity
- Manual clutch operation
- Manual switch control panel (override by remote control)

THE HAWC MINI HAWC

HAWC SHARED SPECS

GENERAL SPECIFICATIONS

- Oscillator gives 30-360° of movement
- Electronically controlled aiming for oscillation function
- Powered adjustable angle of throw 0-35° of height adjustment minimum
- 360° of powered position adjustment
- Central lubrication where practical using Beka-Max components
- 1,000' line of sight radio remote control
- Single control point for "at machine" operation (engine and other functions)
- 5-6 gallon per hour fuel consumption

NOISE LEVEL

- 0 ft = 104 dBA
- 12 ft = 93 dBA

WATER SPECIFICATIONS

- 30 brass nozzles on primary water ring
- 6 brass nozzles on secondary soaking ring
- Separate ball valve control for each water ring
- Quick disconnect water inlet fitting 2" diameter
- Water boosted by 150 PSI after going through booster pump

POWER SPECIFICATIONS

- Electrical components 12 VDC
- 1.0 RPM rotation speed for oscillation
- 1/3 HP, intermittent duty, 12 VDC throw adjustment motor

TIER IV COMPLIANT!

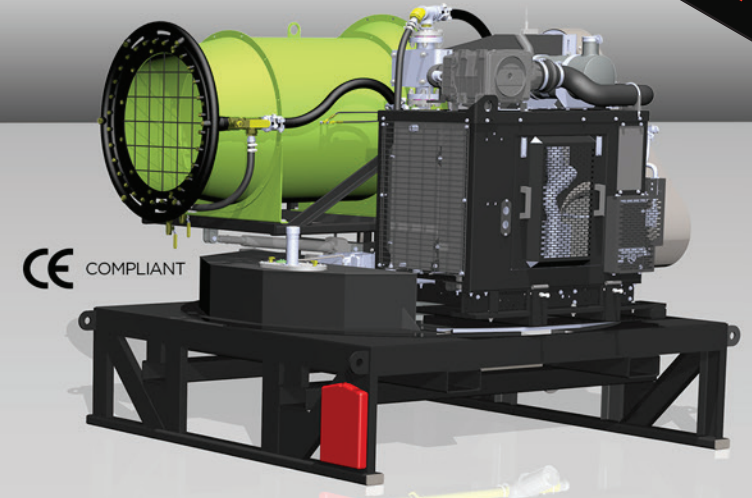

CE COMPLIANT

HAWC 250-65-D specs

Dimensions: 7.5'W x 8'L x 7.1'H

Weight: 6,700 LBS

- 30,000+ CFM generated by 42 HP fan
- Water throw of 250+ feet, 126,000 sq ft coverage
- In-line filter included. (80 mesh, 177 micron)
- 1/3 HP, 12 VDC oscillator motor
- 8,500 feet per minute fan outlet air velocity
- Single control point for "at machine" operation (engine and other functions)
- Logan electric over hydraulic clutch
- Murphy electronic controls

*Water mist throw distance based on 1,000 ft elevation testing

PRIMARY (30) NOZZLE RING

WATER PRESSURE (PSI)	40	60	80	100	120	140	150
WATER FLOW (GPM)	12.0	14.6	16.9	18.9	21.0	22.5	23.3

PRIMARY (30) NOZZLE RING

WATER PRESSURE (PSI)	40	60	80	100	120	140	150
WATER FLOW (GPM)	10.0	12.3	14.1	16.0	17.5	18.7	19.2

SECONDARY (6) NOZZLE RING

WATER PRESSURE (PSI)	40	60	80	100	120	140	150
STANDARD WATER FLOW (GPM)	30	37	43	47	52	55	57
OPTIONAL WATER FLOW (GPM)	60	73	85	95	104	111	114

SECONDARY (6) NOZZLE RING

WATER PRESSURE (PSI)	40	60	80	100	120	140	150
STANDARD WATER FLOW (GPM)	28	32	36	40	43	46	48

Yanmar Tier 3 Diesel Engine

- 4 cycle, in-line, water-cooled diesel
- 80 HP (60 kW) @ 2500 RPM
- 272 lb-ft (270 N-m) @ 1850 RPM
- 3.319L displacement
- EPA Tier 3, EC(NRMM) Stage III Reg.
- 18.1:1 compression ratio
- Yanmar YPD-MP4 fuel system
- 55 gallon fuel tank

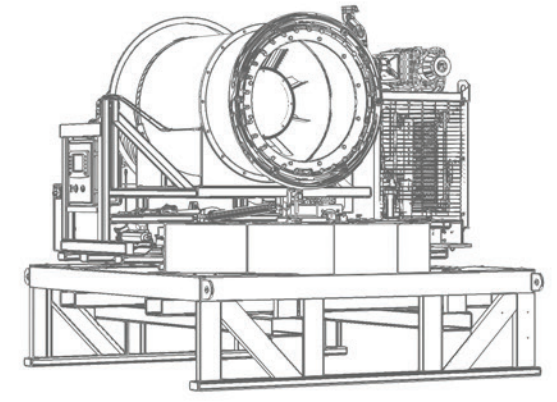
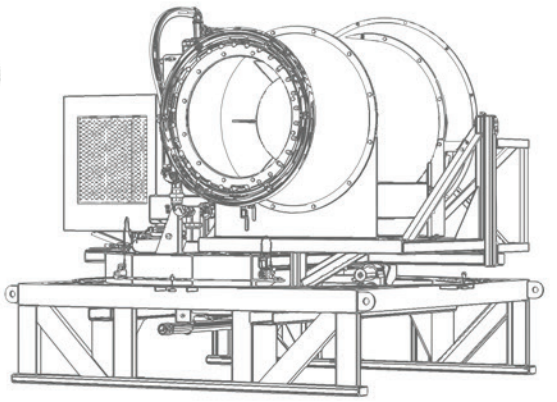

Cummins QSF2.8L Tier 4 Diesel Engine

- 65 HP continuous duty, EPA Tier IV Diesel
- 199 lb-ft (270 N-m) @1600 RPM
- 171 in³ (2.8L) displacement
- Turbocharged, charge air cooled, & EGR
- 16.9:1 compression ratio
- Bosch HPCR fuel system
- 50 gallon fuel tank

THE DUST DEMOLISHER

THE DUST DEMOLISHER

SHARED SPECS

GENERAL SPECIFICATIONS

- Oscillator gives 30-330° of movement
- Electronically controlled aiming for oscillation function
- Powered adjustable angle of throw -10 to +45° of height adjustment
- 330° of powered position adjustment
- Central lubrication where practical using Beka-Max components
- 1,000' line of sight radio remote control
- Single control point for "at machine" operation

NOISE LEVEL

- 0 ft = 104 dBA
- 12 ft = 93 dBA

WATER SPECIFICATIONS

- 30 brass nozzles on primary water ring
- 6 brass nozzles on secondary soaking ring
- Separate ball valve control for each water ring
- Quick disconnect (cam lock) water inlet fitting 2" diameter
- Water boosted by 150 PSI after going through booster pump

POWER SPECIFICATIONS

- 1/4 HP, 480 VAC oscillator motor
- 1.0 RPM rotation speed for oscillation
- Rotation supported by gear driven slewing ring
- 1/2 HP, intermittent duty 120 VAC throw adjustment motor

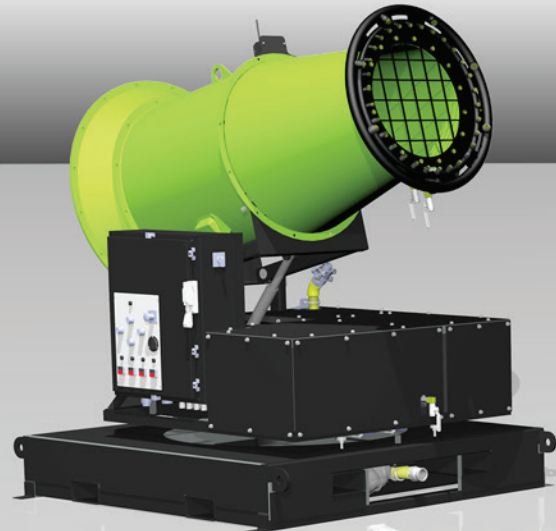

DE 150-480V-E specs

Dimensions: 5.2'W x 7.3'L x 6.8'H

Weight: 3,300 LBS

- 17,000 + CFM generated by fan
- In-line filter included (80 mesh, 177 micron)
- 15 HP, 480 VAC, 3-phase fan motor
- 11 HP, 480 VAC, 3-phase for booster pump
- 7,400 feet per minute fan outlet air velocity

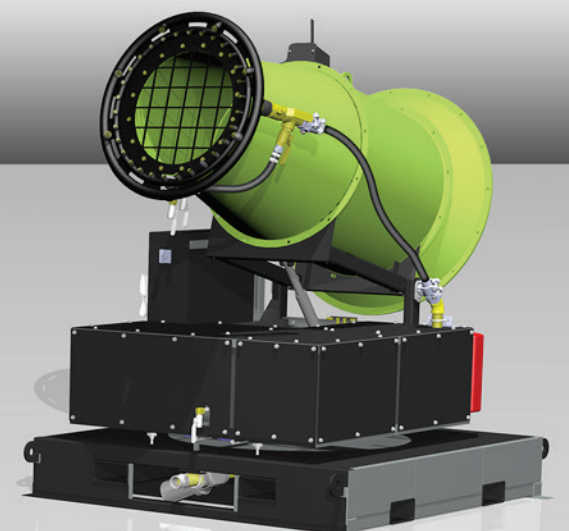

DE 200-480V-E specs

Dimensions: 5.2'W x 7.3'L x 6.8'H

Weight: 3,400 LBS

- 18,000+ CFM generated by fan
- In-line filter included. (80 mesh, 177 micron)
- 20 HP, 480 VAC, 3-phase fan motor
- 13 HP, 480 VAC, 3-phase booster pump
- 8,100 feet per minute fan outlet air velocity

PRIMARY (30) NOZZLE RING

WATER PRESSURE (PSI)	40	60	80	100	120	140	150
WATER FLOW (GPM)	10.0	12.3	14.1	16.0	17.5	18.7	19.2

SECONDARY (6) NOZZLE RING

WATER PRESSURE (PSI)	40	60	80	100	120	140	150
STANDARD WATER FLOW (GPM)	22	25	29	32	34	37	38

WATER COVERAGE AND THROW

- COVERAGE: 65,000 sq ft
- THROW: 150 ft+

*Water mist throw distance based on 1,000 ft elevation testing

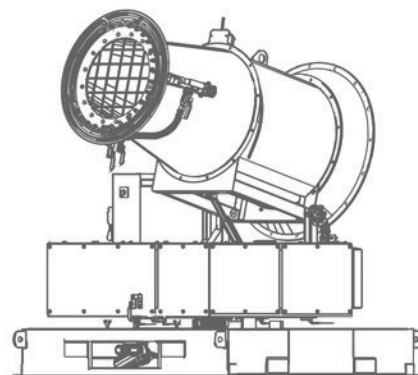

PRIMARY (30) NOZZLE RING

WATER PRESSURE (PSI)	40	60	80	100	120	140	150
WATER FLOW (GPM)	10.0	12.3	14.1	16.0	17.5	18.7	19.2

SECONDARY (6) NOZZLE RING

WATER PRESSURE (PSI)	40	60	80	100	120	140	150
STANDARD WATER FLOW (GPM)	28	32	36	40	43	46	48

WATER COVERAGE AND THROW

- COVERAGE: 115,700 sq ft
- THROW: 200 ft+

*Water mist throw distance based on 1,000 ft elevation testing

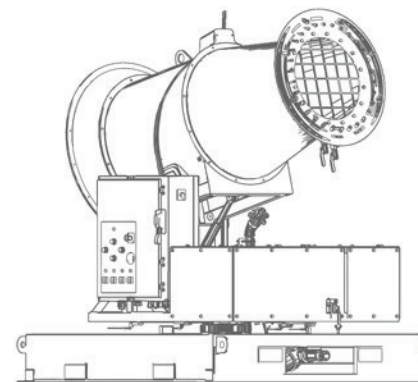

HYDRA PACKAGE



Hydra Package electric powered
 Dimensions: 8'6"W x 23'L x 10'H
 Water Tank: 1,000 gallons
 Weight: 10,200 LBS

THE DUST DEMOLISHER

HYDRA Package

GENERAL SPECIFICATIONS

JUST ADD WATER!

- Package includes integrated water tank/trailer, generator, and Dust Demolisher (DE-150-480V-E or DE-200-480V-E)

POWER SPECIFICATIONS

- DE-150-480V-E packaged with an MQ POWER 45kVA TIER 4 generator
- DE-200-480V-E packaged with an MQ Power 70kVA TIER 4 generator

WATER TANK SPECIFICATIONS

- 1,000 gallon water tank
- 2 HP 480v self-priming centrifugal transfer pump with 3 full load amps
- 16 mesh line strainer between the tank outlet and the transfer pump

THE DUST REGULATOR

Misting System

GENERAL SPECIFICATIONS

- Gyrotary Atomizing Nozzle Misting System
- 3/4 Utility/Garden Hose water input
- 12" outlet size
- Up to 180 degrees oscillation (gas powered unit can be factory customized for up to 270 degrees oscillation)
- Wireless transmitter remote control

POWER SPECIFICATIONS

- 25 HP CH740 Kohler Engine (Gas) or 23 HP KDW1003 Kohler Engine (Diesel)

WATER SPECIFICATIONS

- .33-20 Gallon water volume
- 40-120 PSI water pressure
- 50-200 Micron droplet size



CWX-D1003M diesel powered
 Dimensions: 4'W x 10.5'L x 4.8'H
 Weight: 975 LBS (base unit)
 Ships with 5'x10' wood skid - total weight 1,100 lbs

WATER TRUCKS



2000-2500 gallon trucks
 Ford F750 Chassis



4000-4500 gallon trucks
 7400/7500 International or T370

GENERAL SPECIFICATIONS

- Klein or United "Vision" tanks
- Remote Cannon and Nozzle with Cab Control
- Front, rear, and driver side spray bars/heads
- Automatic transmission
- Backup alarm

GENERAL SPECIFICATIONS

- Lightweight Ceiling-Mounted mister
- High speed atomizer
- Standard 1/2" hose barb fitting
- 22" outlet size
- Up to 10 gallons/hour water volume
- 20-150 microns

POWER SPECIFICATIONS

- 110V AC voltage, 60 HZ frequency, single phase, 5.4 amps, .8 HP, 620 Watt electric motor
- Fan RPM: 3,420; Disk RPM: 1,710

WATER SPECIFICATIONS

- Up to 10 Gallons/hr water volume
- 40-120 PSI water pressure
- 20-150 Micron droplet size

THE DUST MISTER

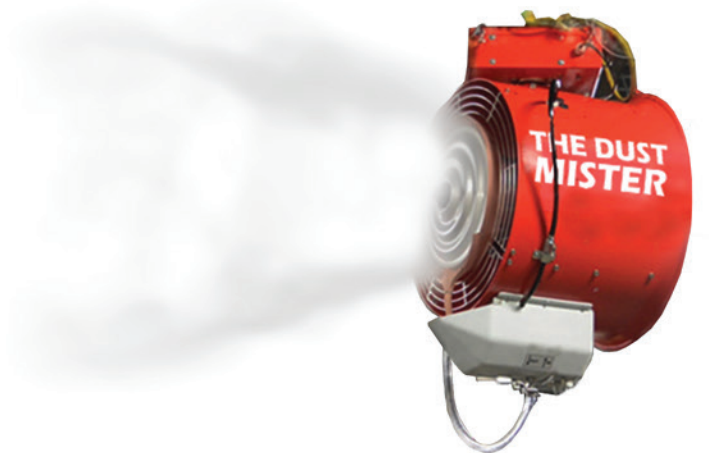

CWX-MCO-110 electric powered
 Dimensions: 25"W x 17"L x 36"H
 Weight: 73 LBS

WATER THROW COMPARISON

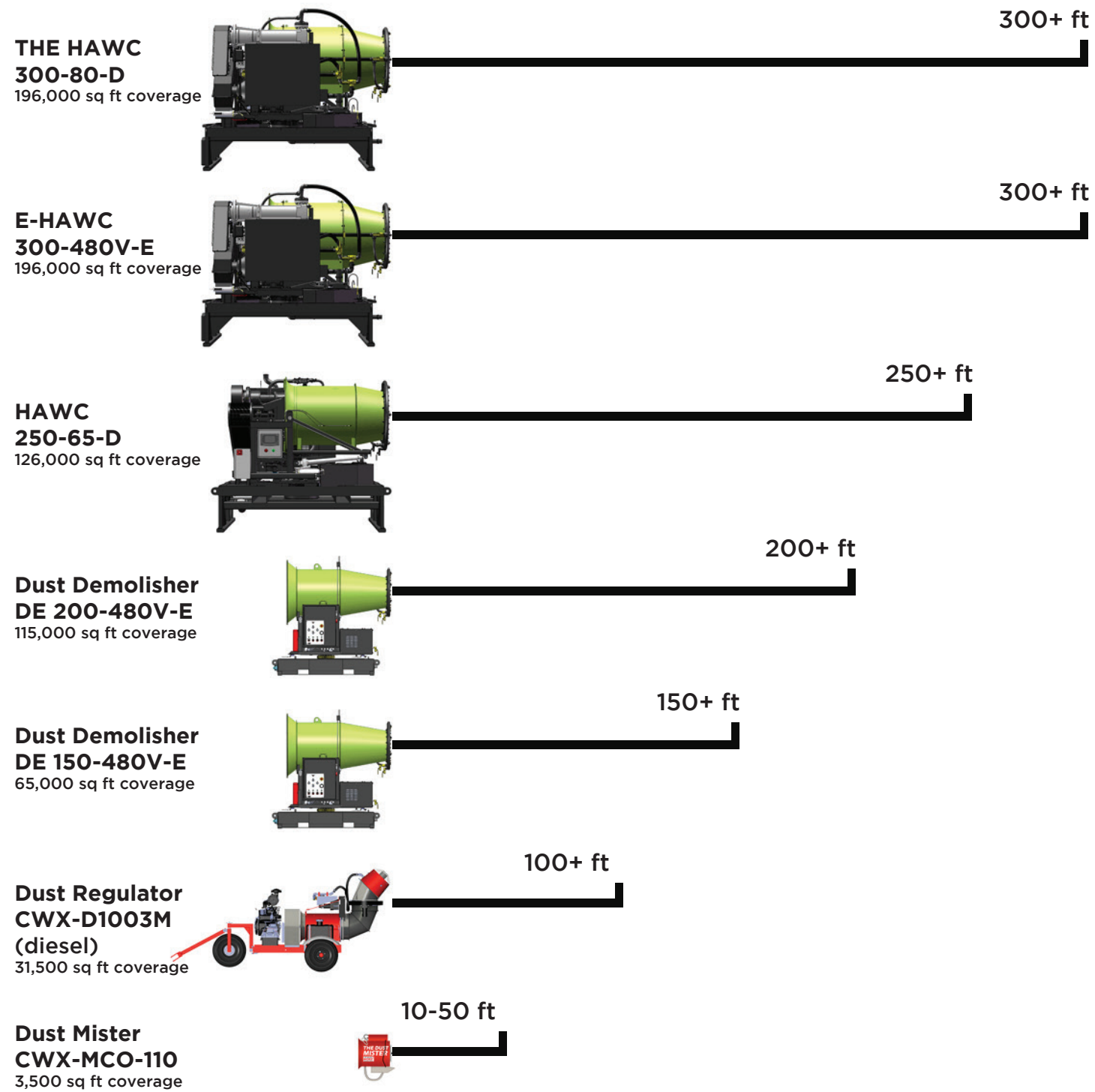

*Distances measured at 1,000 ft above sea level

WE SPECIALIZE IN CUSTOM DUST SUPPRESSION EQUIPMENT



C.W. Machine **WORX**

The Manufacturing Division of Company Wrench

COMPANY WRENCH BRANCH LOCATIONS

KNOXVILLE, TN
6325 Central Ave Pike
Knoxville, TN 37912
Phone: 865-766-2571

CINCINNATI, OH
920 Deneen Ave
Monroe, OH 45050
Phone: 513-402-7297

CLEVELAND, OH
Cleveland, OH 44105
Phone: 440-439-4567

HEADQUARTERS
4805 Scooby Lane
Carroll, OH 43112
Phone: 740-654-5304

WILLIAMSTOWN, NJ
2636 S Black Horse Pike
Williamstown, NJ 08094
Phone: 856-404-9618

CHARLOTTE, NC
11301 Reames Road
Charlotte, NC 28269
Phone: 980-859-4680

COLUMBIA, SC
141 Brickyard Rd
Lexington, SC 29072
Phone: 803-520-0032

LAKELAND, FL
3729 N Frontage Rd.
Lakeland, FL 33810
Phone: 863-937-6829

RALEIGH, NC
125 Wilsons Mills Rd Ext
Smithfield, NC 27577
Phone: 919-938-8145

FOR OTHER DISTRIBUTORS,
CALL 740-808-3130

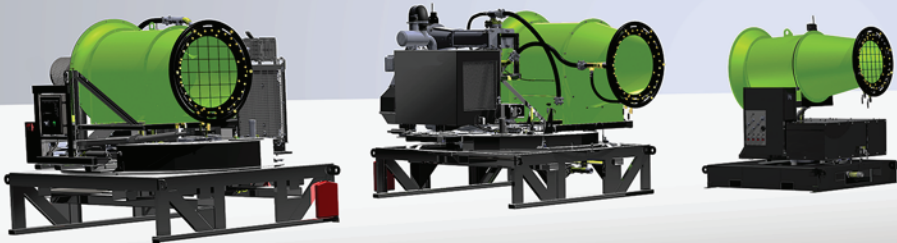

C.W. Machine
WORX
The Manufacturing Division of Company Wrench

Hugh C. Gordon
Sales & Product Manager

4805 Scooby Lane
Carroll, OH 43130
C 740-808-3130
F 866-360-7595



Toll Free 844-4-CWWORX
(429-9679)

h.gordon@companywrench.com
cwmachineworx.com

www.cwmachineworx.com

COPYRIGHT 2017 C.W. MACHINWORX
ALL RIGHTS RESERVED.